

USE H.S. BOLTS WITH HEX. HD. & HEX. NUT, ONE FLAT WASHER UNDER EACH BOLT HEAD AND UNDER EACH NUT.

SIGN AREA SQ. FT.	POST NO.	W SHAPES	BOLT SIZE, LENGTH & MAX. TORQUE	A	B	C	D	E	T ₁	W	R	* CONNECTION WT. IN LBS.
0-85	I	W6 x 15	3/4" x 3-1/4"	6	10 1/4	3/4"	3 1/2	1 1/4	1	5/16	13/32	88
86-120	II	W8 x 18	80 FT.-LB.	6	12 1/2	3/4"	3 1/2	1 1/4	1	5/16	13/32	105
121-170	III	W8 x 24	7/8" x 4" 100 FT.-LB.	8	13 1/8	7/8"	4	2	1 1/4	3/8	15/32	164
171-225	IV	W8 x 31		8	13 1/4							184
OVER 225	V	W8 x 48		8	13 3/4							238

* INCLUDES WEIGHTS OF 2 BASE CONNECTION PLATES, BOLTS, WASHERS, STUB POST, FUSE PLATE AND WELDING. WEIGHT OF POST, ABOVE BASE CONNECTION, SHALL BE COMPUTED AND ADDED FOR EACH LOCATION.

POST NO.	E	H	J	L	M	N	X	Y	d	t	BOLT		PLATE
											DIA.	MIN. LENGTH	wt. in lbs.
I	5 1/4	2 3/4	1 1/4	5	2 3/4	1 1/8	2 1/16	7/8	11/16	3/8	5/8	2 1/4	2.54
II	5 1/4	2 3/4	1 1/4	5	2 3/4	1 1/8	2 1/16	7/8	11/16	3/8	5/8	2 1/4	2.54
III	6 1/2	3 1/2	1 1/2	6 1/2	3 1/2	1 1/2	2	2 1/2	15/16	1/2	7/8	2 3/4	5.63
IV	6 1/2	3 1/2	1 1/2	6 1/2	3 1/2	1 1/2	2	2 1/2	15/16	1/2	7/8	3	5.63
V	6 1/2	3 1/2	1 1/2	6 1/2	3 1/2	1 1/2	2	2 1/2	15/16	1/2	7/8	3	5.63

IF MINIMUM BOLT LENGTHS AS SHOWN IN TABLE ARE NOT AVAILABLE, USE NEXT LONGER STANDARD BOLT LENGTH.

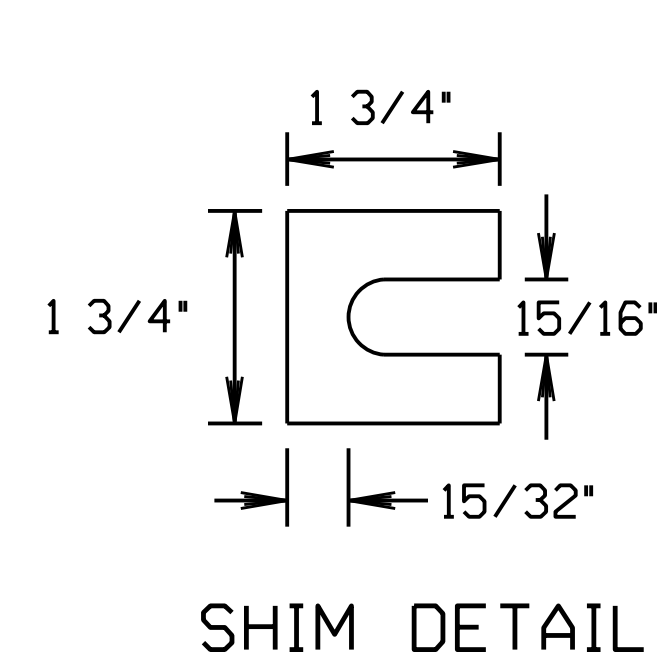

FURNISH 2 s .012" ± THICK AND 2 s .032" ± THICK SHIMS PER POST. SHIMS SHALL BE FABRICATED FROM BRASS SHIM STOCK OR STRIP CONFORMING TO A.S.T.M.-B36.

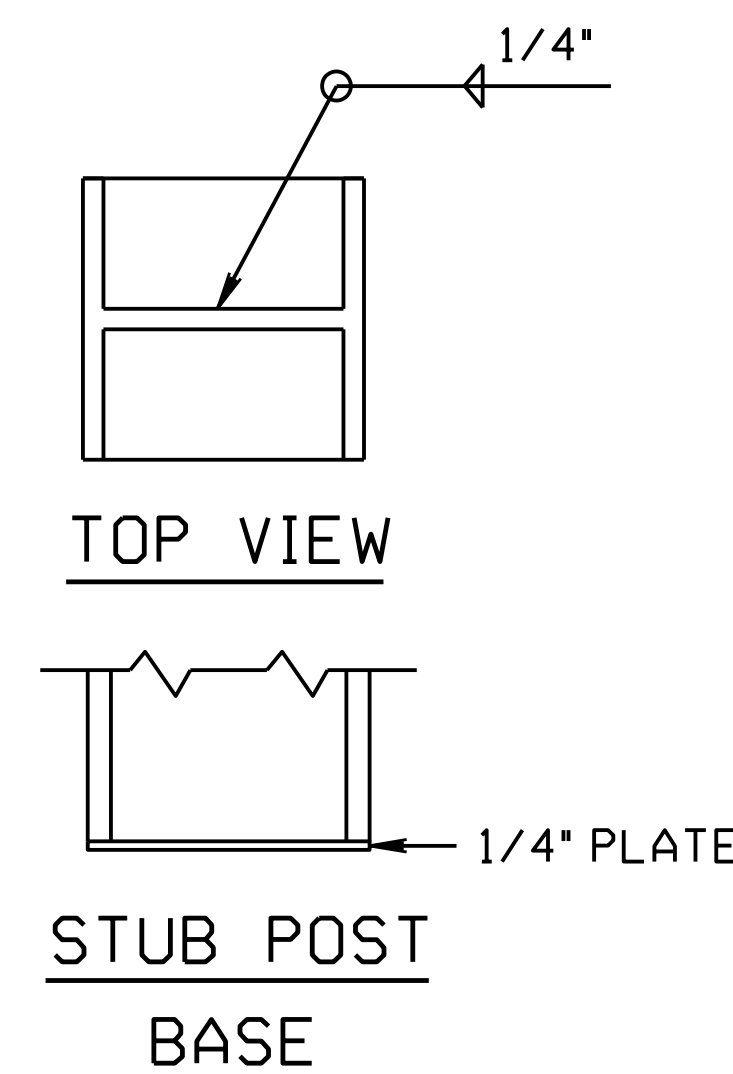

FOR ALL W SHAPES

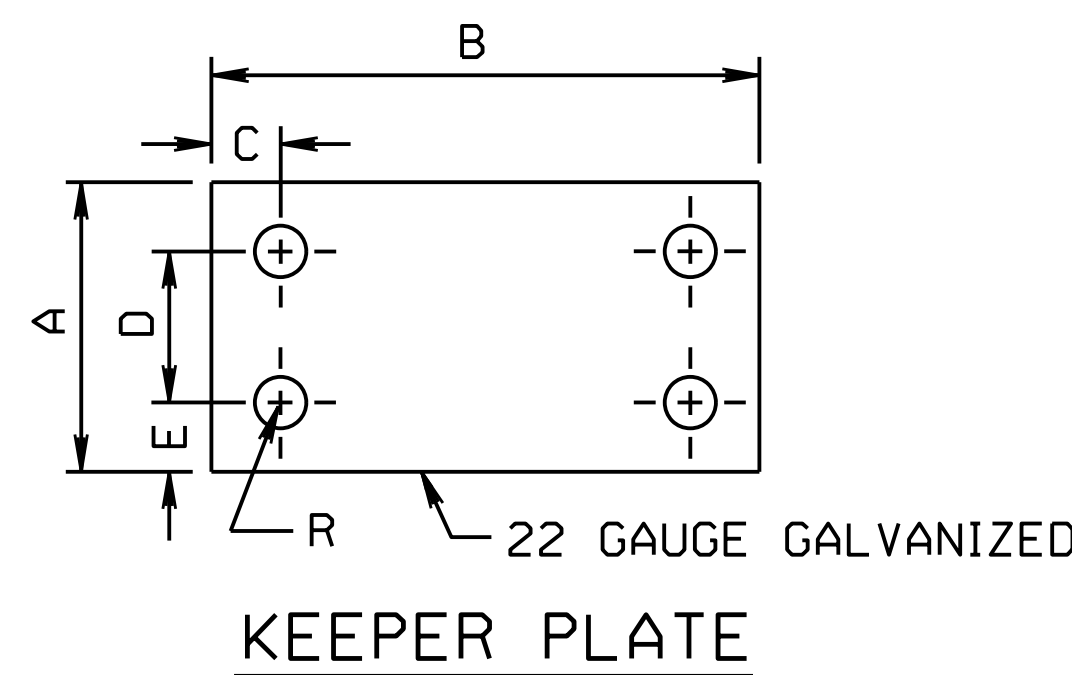

GENERAL NOTES

1. THE FABRICATION OF THE SUPPORTS INVOLVING SUCH OPERATIONS AS CUTTING, DRILLING, WELDING AND CLEANING SHALL BE IN ACCORDANCE WITH SECTION 708. MILL TEST REPORTS SHALL BE SUBMITTED TO THE ENGINEER PRIOR TO FABRICATION.
2. ALL STRUCTURAL STEEL SHALL COMPLY WITH ASTM-A36 OR EQUAL AND SHALL BE GALVANIZED IN ACCORDANCE WITH ASTM-F3125.
3. ALL BOLTS, NUTS AND WASHERS SHALL BE GALVANIZED HIGH STRENGTH STEEL COMPLYING WITH ASTM-A325.

COMPUTER\$\$\$\$\$

DATE\$\$\$\$\$\$\$\$\$\$\$\$\$\$\$\$

DCNSPEC\$\$\$\$\$\$\$\$\$\$\$\$

Project Number

C.N.

W-BEAM SIGN POST INFORMATION

DESIGNED BY
NEBRASKA DEPARTMENT OF TRANSPORTATION - TRAFFIC ENGINEERING DIVISION

DATE

PLAN SHEET NUMBER